

**4JH4-HTE1 Series**

Configuration	4-stroke, vertical, water-cooled diesel engine		
Maximum output at crankshaft	* 71.6 kW@3200 rpm	[100 mhp@3200 rpm]	
Displacement	1.995 ltr	[121.7 cu in]	
Bore x stroke	84 mm x 90 mm	[3.31 in x 3.54 in]	
Cylinders	4, 4-valves per cylinder		
Combustion system	Direct injection		
Aspiration	Turbocharged with intercooler		
Starting system	Electric starting 12V - 1.4 kW		
Alternator	12V - 125A		
Cooling system	Fresh water cooling by centrifugal water pump and rubber impeller sea water pump		
Lubrication system	Enclosed, forced lubricating system		
Direction of rotation [crankshaft]	Counterclockwise viewed from flywheel side		
Dry weight without gear	217 kg	[478 lbs]	
Environmental	EU: RCD	BSO II	EMC
	US: EPA Tier 3		
Engine mounting	Rubber type flexible mounts		

NOTE:

Fuel condition: Density at 15°C = 0.84 g/cm<sup>3</sup>; 1 kW = 1.3596 mhp = 1.3410 HP

\* Fuel temperature 40°C at the inlet of the fuel injection pump [ISO 8665]

Technical data is according to ISO 8665: 2006/3046-1

DIMENSIONS

Rear view

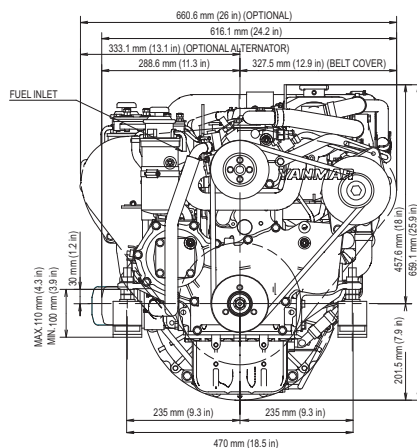

Right side view

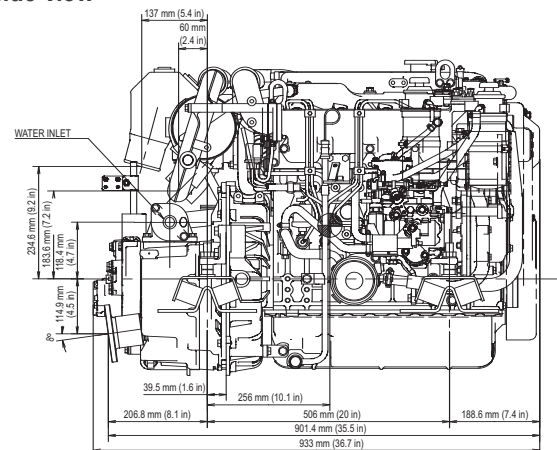

4JH4-HTE with KMH4A marine gear

## PERFORMANCE CURVES

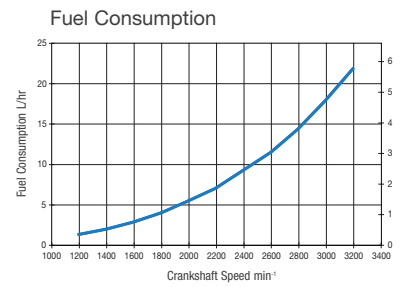
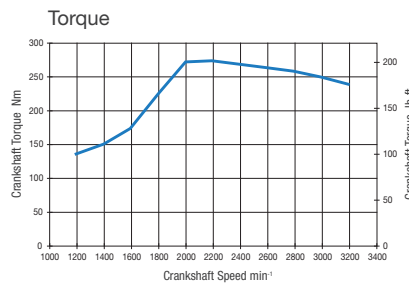
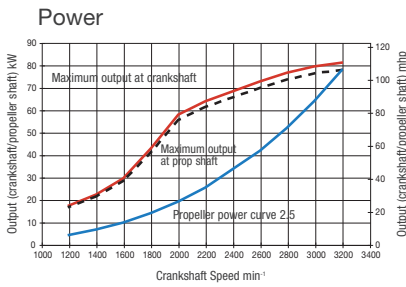

## MARINE GEARS/DRIVE

Model	ZF30M parallel		KM4A2 [down angle: 7°]			KMH4A [down angle: 8°]		ZF25A [down angle: 8°]	
Type	Mechanical multi-disc		Mechanical wet cone clutch			Hydraulic, wet multi-disc		Hydraulic, wet multi-disc	
Dry Weight	28 kg [61 lbs]		30 kg [66 lbs]			31 kg [68 lbs]		30 kg [66 lbs]	
Reduction Ratio [fwd/asn]	2.15/2.64	2.70/2.64	1.47/1.47	2.14/2.14	2.63/2.63	2.04/2.04	2.45/2.45	1.93/1.93	2.48/2.48
Propeller speed at cont. rating [fwd/asn]	1488/1212	1185/1212	2177/2177	1495/1495	1217/1217	1569/1569	1306/1306	1658/1658	1290/1290
Direction of rotation [propeller shaft - fwd]	Clockwise viewed from flywheel side		Clockwise & Counterclockwise viewed from flywheel side			Clockwise & Counterclockwise viewed from flywheel side		Clockwise & Counterclockwise viewed from flywheel side	
Dry weight - engine & gear	245 kg [540 lbs]		247 kg [545 lbs]			248 kg [547 lbs]		247 kg [545 lbs]	
Length engine and gear/drive	923 mm [36 in]		903 mm [35 in]			933 mm [37 in]		1017 mm [40 in]	

## INSTRUMENT PANELS

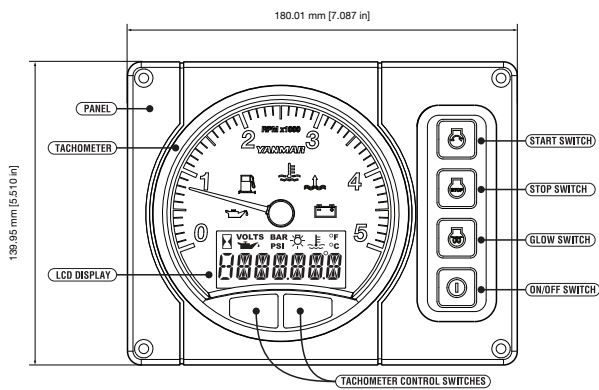

B20 STANDARD

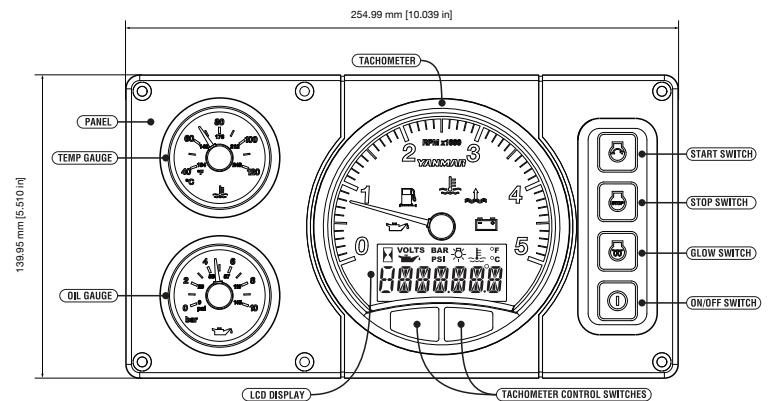

C30 OPTIONAL

## ACCESSORIES

### Standard Package

- Set of flexible mounts
- Exhaust mixing elbow [L-type]
- V-belt safety cover
- Expansion tank for fresh water cooling system
- Alternator 12V - 125A
- Electric stop solenoid
- Operation manual
- B20-panel
- Sensor for instrument panel

### Optional

- Second alternator 12V - 130A or 24V - 75A, including smart regulator
- High-riser mixing elbow [insted of L-elbow]
- Extension wire harnesses [4m, 6m 10m]
- Hot water kit with cocks
- Second station harness
- C30-panel
- Sensor for C-30 panel

NOTE: All data subject to change without notice. Text and illustrations are not binding.